

**Shri Guru Gobind Singhji**  
**Institute of Engineering & Technology, Vishnupuri, Nanded 431606**

No. SGGSI&T/Mech/PE114/ Gears for Front Gearbox Optimization/2022-23/ 1208 Date: 05/09/2022

**Inquiry**

**Subject: - Quotation for supply of Gear for Front Gearbox Optimization for Team Phoenix (Mechanical Engineering)**

Dear Sir,

You are requested to send your most competitive quotation for the supply of the following material, subject to the Terms and Conditions mentioned,

SN	Name of the material	Material	Specifications	Required Quantity
1	Gear for Front Gearbox Optimization	20MnCr5	For detailed specs please refer enclosed design	01 Unit

The quotation in a sealed envelope should reach this office (Director, SGGI Institute of Engineering and Technology, Vishnupuri, Nanded – 431606) on or before **16/09/2022** at 04:00 pm.

The sealed envelope should be superscribed as

**“QUOTATION for Gears for Front Gearbox Optimization due on 16/09/2022 at 04 pm”.**

The quotation will be opened on **19/09/2022** at 01:00 pm, if possible, in the presence of such suppliers who remain present.

**Terms and Conditions:**

1. Rates quoted are F.O.R. at Vishnupuri.
2. The taxes, Insurance, Freight, Packing & forwarding charges etc. If any must mention it separately.
3. The validity period for the rates offered should be clearly mentioned and it should be 90 days from the date of opening of the quotations.
4. The delivery period shall be clearly stated.
5. The item quoted should be confirmed to the specification given please furnish your Details Specification against each item quoted. The relevant catalogue/pamphlet should necessarily accompany the quotations.
6. The institution reserves the right to accept any quotation or reject any/all quotations and to order Any of the items in any quantity without assigning any reason
7. The items will have been checked at the institute and acceptance is subject to the approval of the institute.
8. If the supply of any part thereof is rejected by the institute the supplier will have to bear all expenses. Incurred in the matter including all charges for return and replacement of the items.
9. Guarantee should be a minimum of 12 months from demonstration/installation.
10. 100% payment will be made after receipt of material in good condition and approved by us.
11. If you are having DGS&D rate contract, or your item is proprietary then please send a copy of the rate contract or proprietary item certificate along with an authorized dealership certificate.
12. If your item/s is /are a PROPRIETARY item, then you may please send the PROPRIETARY ITEM CERTIFICATE along with the quotation.
13. If you are an AUTHORISED DEALER of any manufacturers, then please send the dealership Certificate and company price list along with the quotation.
14. Penalty clause: If a supplier fails to supply the ordered material within the scheduled delivery period, for late delivery of goods we will be entitled to recover the liquidated damages as a sum equal to ½ per cent of the price of stores delivered late per week. As per store purchase manual Revised as per G.O (P) No.3/2013/SPD, dated 21.06.2013.

Thanking You,

  
Head  
Mechanical Engineering Department  
**Mechanical Engineering Department**  
**S.G.G.S.I.E. & T. Nanded.**

1/6

Annexure - A

# Exploded View:

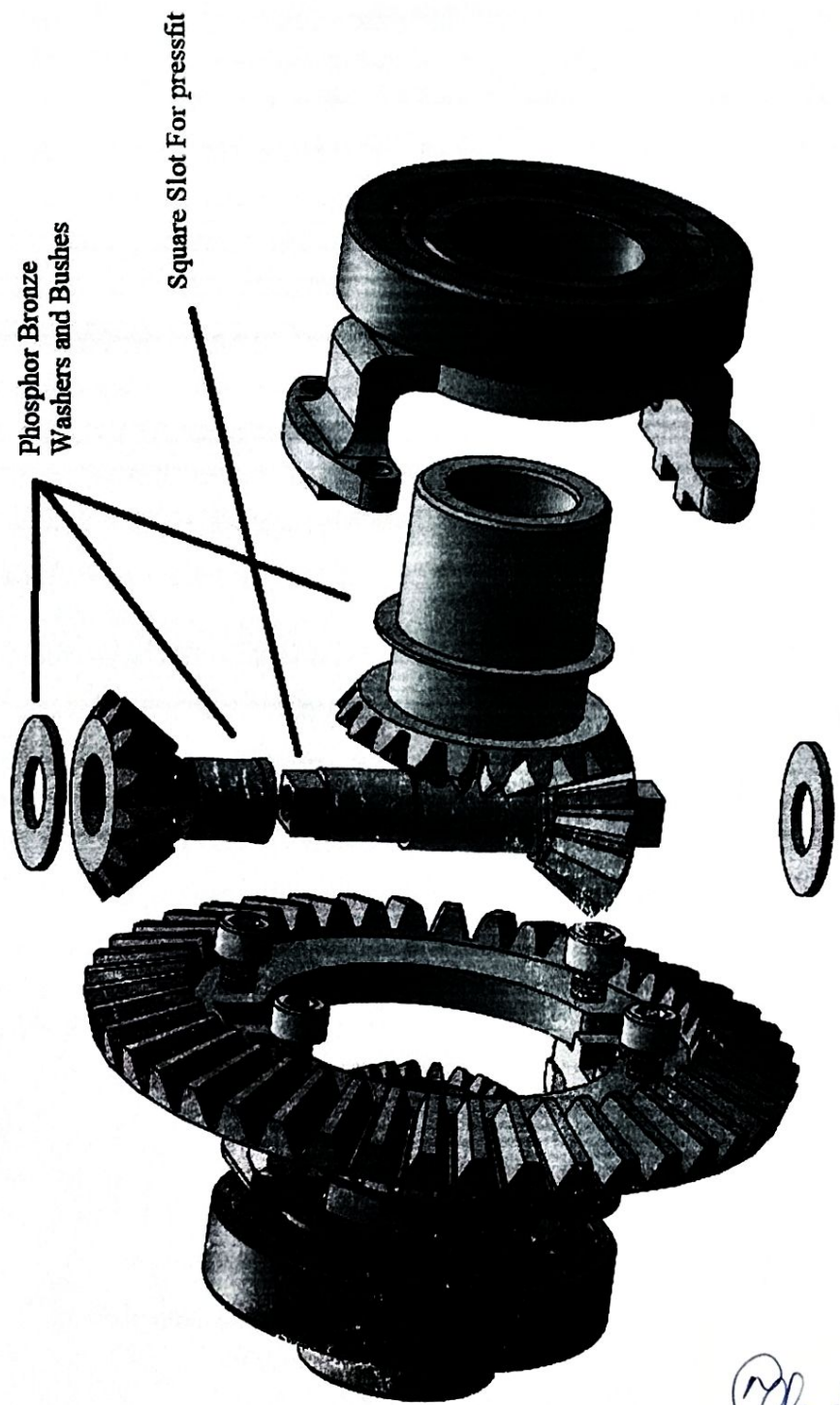

*Rajesh P. Parvekar*  
30/8/22

**Rajesh P. Parvekar**  
Assoc. Professor (CAS) and  
Head  
Mechanical Engineering Department  
S.G.S.I.E. & T., Nanded

Mechanical Engineering Department  
S.G.S.I.E. & T., Nanded  
Assoc. Professor (CAS) and  
Head





6 5 4 3 2 1

D C B A

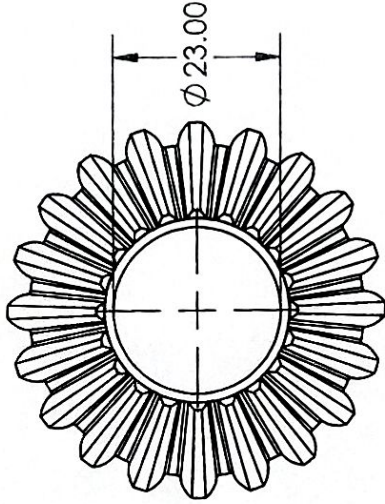
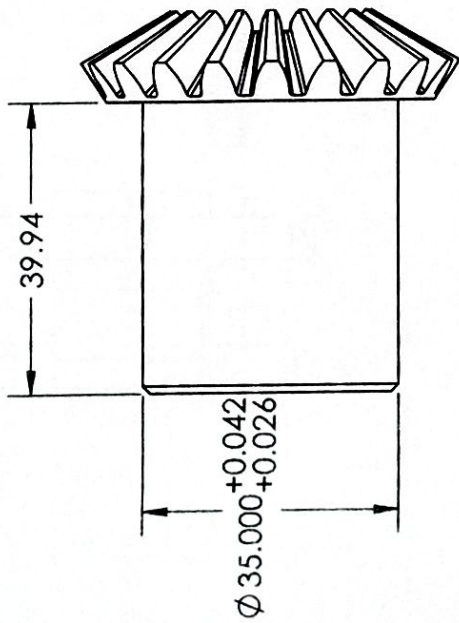

*Done.*  
 T.R. Yelme  
 Captain  
 Team Phoenix

  
**Rajesh P. Parvekar**  
 Assoc. Professor (CAS) and  
 Head  
 Mechanical Engineering Department  
 S.G.G.S.I.E.&T., Nanded

UNLESS OTHERWISE SPECIFIED: DIMENSIONS ARE IN MILLIMETERS		FINISH:	DEBURRE AND BREAK SHARP EDGES		DO NOT SCALE DRAWING	REVISION
SURFACE FINISH:		NAME		TITLE		<b>Hside Gear</b> 
TOLERANCES:		SIGNATURE	DATE		DWG NO.	
LINEAR:		MATERIAL:		SCALE: 1:1	A4	
ANGULAR:		WEIGHT:		SHEET 1 OF 1		
DRAWN		20MnCr5				
CHKD						
APPVD						
MFG						
Q.A						

6 5 4 3 2 1

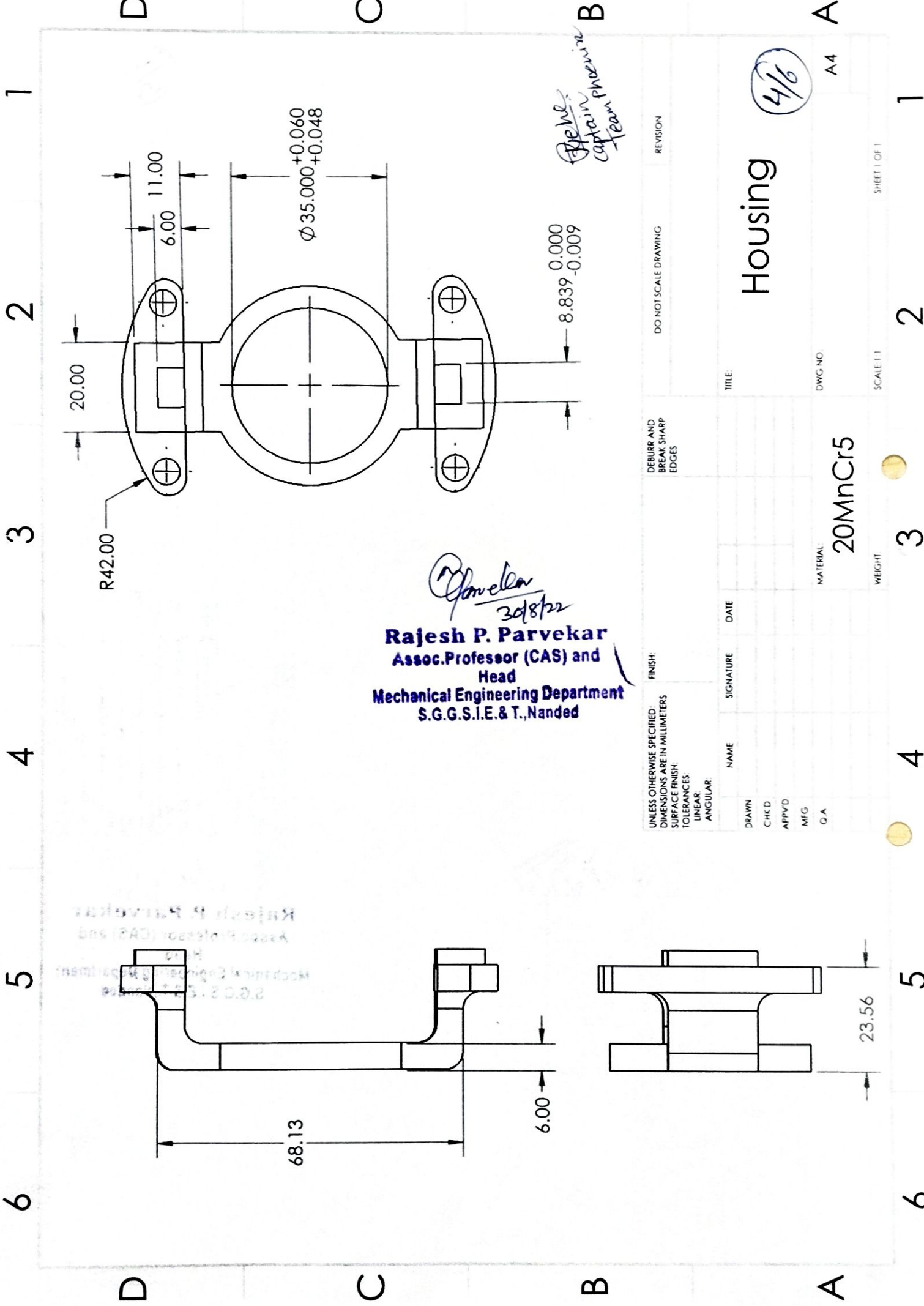

  
**Rajesh P. Parvekar**  
 Assoc. Professor (CAS) and  
 Head  
 Mechanical Engineering Department  
 S.G.G.S.I.E. & T., Nanded

Rajesh  
 Captain Parvekar  
 Team

UNLESS OTHERWISE SPECIFIED: DIMENSIONS ARE IN MILLIMETERS		FINISH:	DO NOT SCALE DRAWING	REVISION
SURFACE FINISH:		DEBURR AND BREAK SHARP EDGES		
TOLERANCES:				
LINEAR				
ANGULAR				
DRAWN	NAME	SIGNATURE	DATE	TITLE: <b>Housing</b>
CHK'D				<b>4/6</b>
APP'VD				A4
MFG				
G.A				
MATERIAL: <b>20MnCr5</b>		DWG NO.		
WEIGHT		SCALE 1:1	SHEET 1 OF 1	



6 5 4 3 2 1

D C B A

D C B A

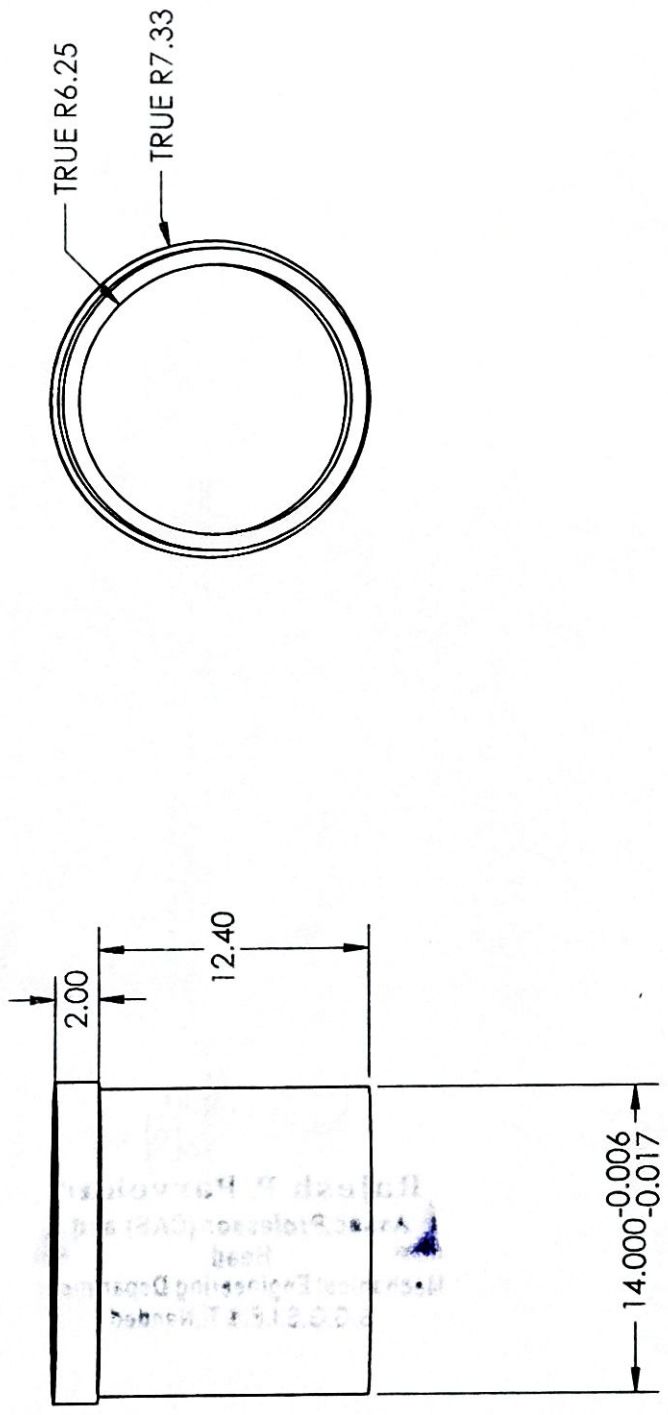

*Rajesh P. Parvekar*  
 Captain,  
 Team Phoenix

UNLESS OTHERWISE SPECIFIED: DIMENSIONS ARE IN MILLIMETERS				FINISH:		DEBURR AND BREAK SHARP EDGES		DO NOT SCALE DRAWING		REVISION	
SURFACE FINISH:				NAME		SIGNATURE		TITLE		DWG NO.	
TOLERANCES				DRAWN		CHK'D		Phosper Bronze bushing		A4	
LINEAR:				APPR'D		MFG		5/6		SCALE: 3:1	
ANGULAR:				DATE		MATERIAL:		SHEET 1 OF 1			
				WEIGHT:							

*Rajesh P. Parvekar*  
 30/8/22  
**Rajesh P. Parvekar**  
 Assoc. Professor (CAS) and  
 Head  
 Mechanical Engineering Department  
 S.G.G.S.I.E. & T., Nanded

1 2 3 4 5 6

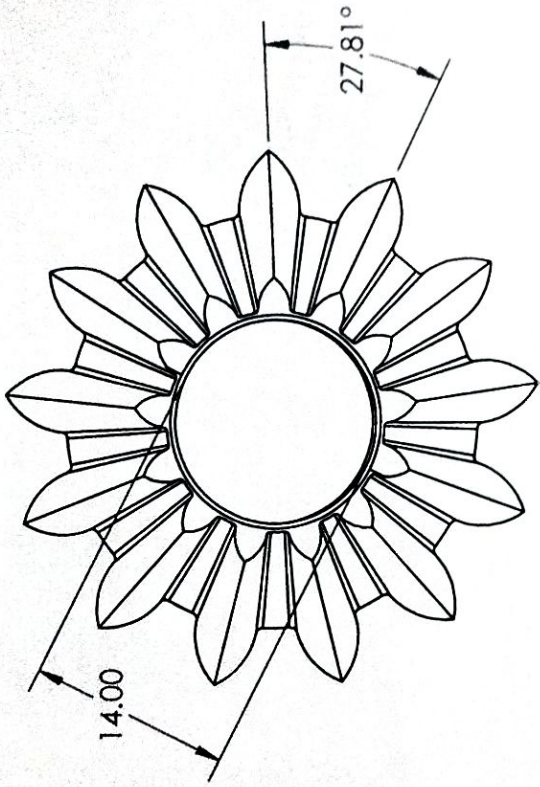
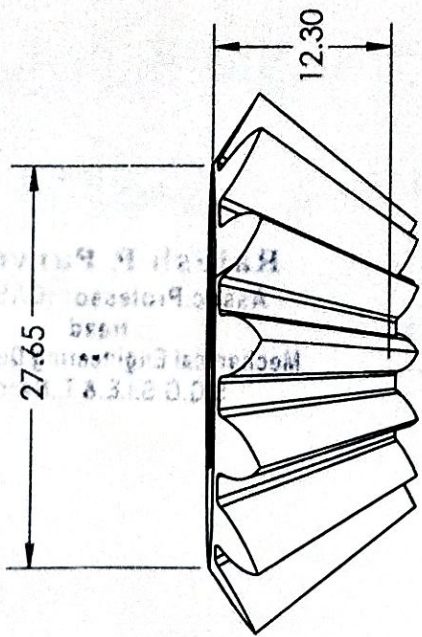

*Rajesh P. Parvekar*  
 Captain  
 Team Phoenix

*Rajesh P. Parvekar*  
 30/8/22  
**Rajesh P. Parvekar**  
 Assoc. Professor (CAS) and  
 Head  
 Mechanical Engineering Department  
 S.G.G.S.I.E. & T., Nanded

UNLESS OTHERWISE SPECIFIED: DIMENSIONS ARE IN MILLIMETERS		FINISH:	DEBURR AND BREAK SHARP EDGES	DO NOT SCALE DRAWING	REVISION
SURFACE FINISH:					
TOLERANCES:					
LINEAR:					
ANGULAR:					
NAME	SIGNATURE	DATE	TITLE	TITLE	
				Spider Gear	
DRAWN				DWG NO.	6/6 A4
CHK'D				MATERIAL	20Mnr5
APP'VD				SCALE: 2:1	3
MFG				WEIGHT	3
G.A				SHEET OF 1	1



6 5 4 3 2 1

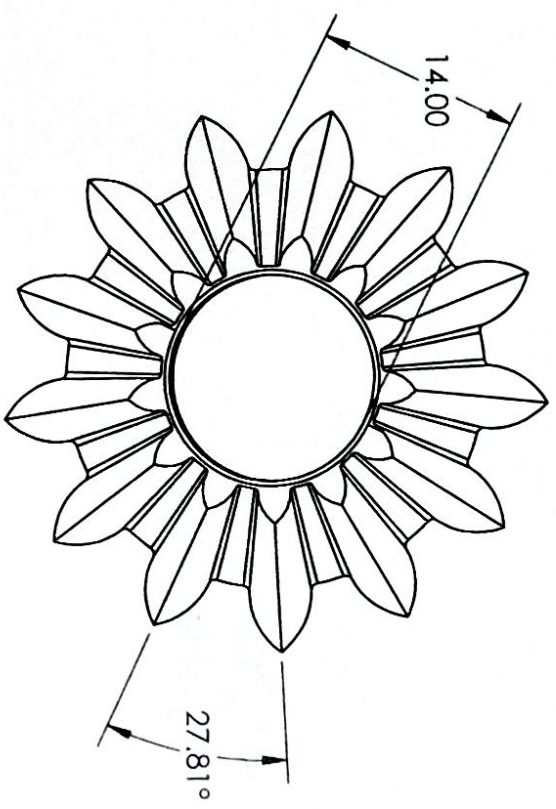
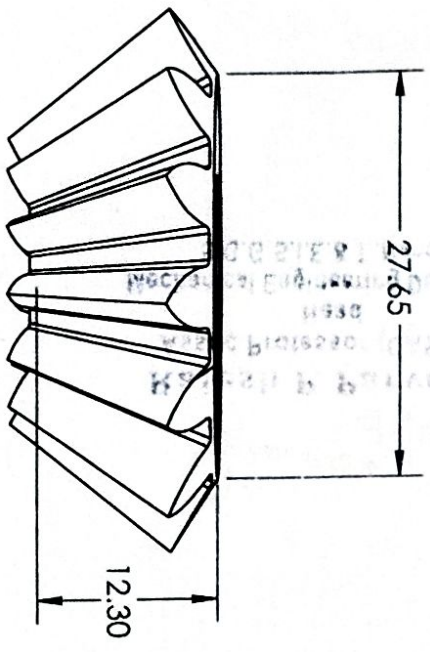

**Rajesh P. Parvekar**  
 Assoc. Professor (CAS) and  
 Head  
 Mechanical Engineering Department  
 S.G.G.S.I.E.&T., Nanded  
*Rajesh P. Parvekar*  
 30/8/22

*Rajesh P. Parvekar*  
 Captain  
 Team Phoenix

UNLESS OTHERWISE SPECIFIED: DIMENSIONS ARE IN MILLIMETERS		FINISH:	DO NOT SCALE DRAWING	REVISION
SURFACE FINISH:				
TOLERANCES:				
LINEAR:				
ANGULAR:				
DRAWN	NAME	SIGNATURE	DATE	TITLE
CHKD				
APPR'D				
MFG				
CA				
MATERIAL: 20Mnr5		DWG NO:		
WEIGHT:		SCALE: 2:1		
		SHEET 1 OF 1		
		A4		

**Spider Gear**

6/16  
 A4

A B C D A B C D

6 5 4 3 2 1